

## Do Localized Structures of [14]- and [18]Annulenes Exist?

Cheol Ho Choi and Miklos Kertesz\*

Department of Chemistry, Georgetown University  
Washington, DC 20057-1227

Alfred Karpfen

Institute for Theoretical Chemistry and  
Radiation Chemistry, University of Vienna  
Währingerstrasse 17, A-1090 Vienna, Austria

Received April 1, 1997

Revised Manuscript Received September 8, 1997

Bond length alternation ( $\delta = R_{\text{single}} - R_{\text{double}}$ ) of  $\pi$ -conjugated systems has been recognized as one of the good measures of  $\pi$ -electron delocalization, or aromaticity. The famous Hückel rule of aromaticity<sup>1</sup> dictates that  $\pi$ -conjugated systems with  $(4n + 2)$   $\pi$ -electrons are aromatic and, consequently, their C–C bond lengths are supposed to be close to that of benzene, **1**, 1.40 Å ( $\delta = 0$ ). Recent studies<sup>2</sup> have suggested that the  $D_{6h}$  symmetry of benzene originates from the dominating  $\sigma$ -electrons rather than  $\pi$ -electrons which tend to localize. On the other hand, the application of Peierls' theorem<sup>3,4</sup> on the nonexistence of a 1-dimensional metal to the  $\pi$ -electrons of an infinite  $\pi$ -conjugated polyene, **14**, implies that in the limit of  $n \rightarrow \infty$  the ground state should be the symmetry breaking (bond length alternating) structure ( $\delta \neq 0$ ). Although the actual value of  $\delta$  in polyacetylene (the polymeric form of polyene) is still somewhat uncertain, it is generally believed to lie between 0.05<sup>5</sup> and 0.08<sup>6</sup> Å.

It has been widely assumed that all conjugated annulenes which satisfy the Hückel  $4n + 2$  rule, except benzene, can have both bond alternating (bond localized) and nonalternating (aromatic) structures, as suggested by theoretical studies with various semiempirical,<sup>7</sup> molecular mechanics,<sup>8</sup> and HF methods<sup>9</sup> (**6**, **11**). However, inclusion of electron correlation effects within the semiempirical methods<sup>7,10</sup> and MP2 single point energy evaluation at HF optimized geometry<sup>11a</sup> prefer the nonalternating structure (**7**, **12**). Recently, Yoshizawa et al.<sup>10</sup> have calculated large annulenes (up to [66]annulene) using MNDQC (C for correlation) and have shown that, in [18]annulene, **9**, and **10** the aromatic  $D_{6h}$  structure is more favorable, but in [30]annulene the  $D_{6h}$  structure is less stable than the bond localized  $D_{3h}$  structure. Recent DFT calculations<sup>11b</sup> also support **9** over **10**.

This possibility of three local minima along the  $\delta$  (Kekulé) coordinate, **6**, **7**, **11**, and **12**, has been generally assumed and is

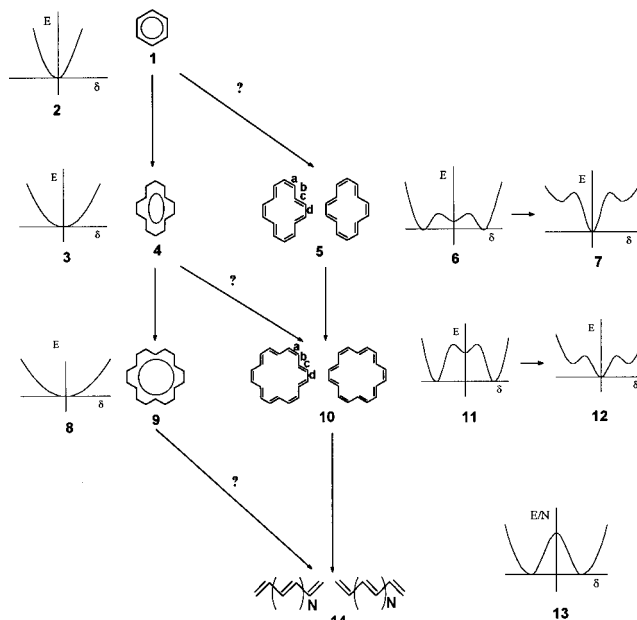

at the core of the controversy regarding the aromaticity of these simple annulenes. Full geometry optimization of [14]annulene, **4**, **5**, and [18]annulene with *ab initio* electron correlation methods has been lacking in the literature except very recently.<sup>11b</sup> On the other hand, Paldus et al.<sup>12</sup> have done semiempirical calculations on a series of cyclic polyenes incorporating electron correlation and have shown that the “transition” from single minimum (**2**, **3**, **8**) to two minima (**13**) occurs with increasing size at [14]annulene without the three minima intermediate situation.

In this paper, two important annulenes, [14]annulene and [18]annulene, have been studied with HF/6-311G\*, BLYP/6-311G\*,<sup>13</sup> B3LYP/6-311G\*,<sup>14</sup> and MP2<sup>15</sup>/6-31G\* methods to obtain reliable potential energy surface along the  $\delta$  coordinate.

Chiang and Paul<sup>16</sup> determined the X-ray structure of [14]annulene in 1972. They found that it is aromatic with significant nonplanarity originating from the steric hindrance of the four internal hydrogen atoms in the center of the molecule and that the C–C bond lengths range from 1.350 to 1.407 Å. However, 1.350 Å is clearly too small to be an aromatic C–C bond length and equals Dewar's minimum bond length of nonaromatic systems.<sup>17</sup> Molecular mechanics calculations,<sup>8</sup> semiempirical calculations,<sup>7</sup> and our full geometry optimizations (see Table 1) have not reproduced these small bond lengths which is likely due to the<sup>16</sup> small number of reflection data points in the structure refinement. Gorter et al.<sup>18</sup> have discovered unexpected disorder in the crystal [18]annulene and shown that it has approximate  $D_{6h}$  symmetry with 1.385 Å inner and 1.405 Å outer C–C bond lengths confirming the aromatic structure in the crystal. This bond length difference (0.020 Å) is much smaller than that (0.037 Å) extracted from X-ray data by Bregman et al.,<sup>19</sup> and even smaller than a recent theoretical value (0.052 Å) by Capponi et al.,<sup>20</sup> but it is well reproduced by the BLYP, B3LYP, and MP2 methods (see Table 1).

(1) Garratt, P. G. *Aromaticity*; McGraw-Hill: London, 1971.  
 (2) (a) Jug, K.; Köster, A. M. *J. Am. Chem. Soc.* **1990**, *112*, 6772. (b) Hiberty, P. C.; Danovich, D.; Shurki, A.; Shaik, S. *J. Am. Chem. Soc.* **1995**, *117*, 7760. (c) Haas, Y.; Zilberg, S. *J. Am. Chem. Soc.* **1995**, *117*, 5387.  
 (3) (a) Peiels, R. *Quantum Theory of Solids*; Oxford University Press: New York, 1955. (b) Longuet Higgins, H. C.; Salem, L. *Proc. R. Soc. London, Ser. A* **1959**, *25*, 172.  
 (4) (a) Ovchinnikov, A. A.; Ukrainskii, I. I.; Kventsel, G. F. *Usp. Fiz. Nauk.* **1972**, *108*, 81. (b) Kertesz, M. *Adv. Quantum Chem.* **1982**, *15*, 161. (c) Heeger, A. J.; Kivelson, S.; Schrieffer, J. R.; Su, W.-P. *Rev. Modern Phys.* **1988**, *60*, 781. (d) Mintmire, J. W.; White, C. T. *Phys. Rev.* **1987**, *B35*, 4180.  
 (5) Choi, C. H.; Kertesz, M.; Karpfen, A. *J. Chem. Phys.* In press.  
 (6) (a) Fincher, C. R., Jr.; Chem, C.-E.; Heeger, A. J.; MacDiarmid, A. G. *Phys. Rev. Lett.* **1982**, *48*, 100. (b) Yannoni, C. S.; Clarke, T. C. *Phys. Rev. Lett.* **1983**, *51*, 1191. (c) Kahlert, H.; Leitner, O.; Leising, G. *Synth. Met.* **1987**, *17*, 467. (d) Zhu, Q.; Fisher, J. E. *Solid State Commun.* **1992**, *83*, 179.  
 (7) (a) Baumann, H. *J. Am. Chem. Soc.* **1978**, *100*, 7196. (b) Jug, K.; Fasold, E. *J. Am. Chem. Soc.* **1987**, *109*, 2263. (c) Baumann, H.; Oth J. F. M. *Helv. Chim. Acta* **1995**, *78*, 679.  
 (8) Allinger, N. L.; Sprague, J. T. *J. Am. Chem. Soc.* **1973**, *95*, 3893.  
 (9) Haddon, R. C.; Raghavachari, K. *J. Am. Chem. Soc.* **1985**, *107*, 289.  
 (10) Yoshizawa, K.; Kato, T.; Yamabe, T. *J. Phys. Chem.* **1996**, *100*, 5697.  
 (11) (a) Schulman, J. M.; Disch, R. L. *J. Mol. Struct. (Theochem)* **1991**, *234*, 213. (b) Jiao, H.; Schleyer, P. v. R. *Angew. Chem., Int. Ed. Engl.* **1996**, *35*, 2383. Baldrige, K. K.; Siegel, J. S. *Angew. Chem., Int. Ed. Engl.* **1997**, *36*, 745.

(12) (a) Takahashi, M.; Paldus, J. *Int. J. Quantum Chem.* **1984**, *26*, 349. (b) Takahashi, M.; Paldus, J. *Int. J. Quantum Chem.* **1985**, *28*, 459. (c) Li, X. Z.; Paldus, J. *Int. J. Quantum Chem.* **1996**, *60*, 513.  
 (13) (a) Becke, A. D. *Phys. Rev. A* **1988**, *38*, 3098. (b) Lee, C.; Yang W.; Parr, R. G. *Phys. Rev. B* **1988**, *37*, 785.  
 (14) Becke, A. D. *J. Chem. Phys.* **1993**, *98*, 5648.  
 (15) (a) Hehre, W. J.; Radom, L.; Schleyer, P. v. R.; Pople, J. A. *Ab Initio Molecular Orbital Theory*; Wiley: New York, 1986. (b) Frisch, M. J.; et al.; Gaussian, Inc.: Pittsburgh, PA, 1995.  
 (16) Chiang, C. C.; Paul, I. C. *J. Am. Chem. Soc.* **1972**, *94*, 4741.  
 (17) Dewar, M. J. S. *The Molecular Orbital Theory of Organic Chemistry*; McGraw-Hill: New York, 1969; p 179.  
 (18) Gorter, S.; Keulemans-Rutten, E.; Krever, M.; Romers, C.; Cruickshank, D. W. J. *Acta Crystallogr.* **1995**, *B51*, 1036.

**Table 1.** Experimental and Theoretical Bond Lengths and Relative Energies of [14]- and [18]Annulenes

		$a^a$	$b^a$	$c^a$	$d^a$	$E(\text{rel})^b$
[14]Annulene						
exptl <sup>c</sup>		1.407	1.350	1.382	1.395	
SINDO1 <sup>d</sup>	(C <sub>2h</sub> )	1.423	1.418	1.424	1.422	0
	(C <sub>s</sub> )	1.368	1.484	1.368	1.509	6.6
MINDO/3 <sup>e</sup>	(C <sub>i</sub> )	1.410	1.399	1.398	1.403	18.0
	(C <sub>s</sub> )	1.354	1.476	1.355	1.483	0
HF/6-311G* <sup>f</sup>	(C <sub>i</sub> )	1.399	1.388	1.388	1.401	18.6
	(C <sub>2h</sub> )	1.399	1.388	1.388	1.401	18.6
	(C <sub>s</sub> )	1.337	1.462	1.331	1.478	0
BLYP/6-311G* <sup>f</sup>	(C <sub>s</sub> ) <sup>g</sup>	1.416	1.404	1.404	1.420	
B3LYP/6-311G* <sup>f</sup>	(C <sub>s</sub> ) <sup>g</sup>	1.404	1.393	1.393	1.407	
MP2/6-31G* <sup>f</sup>	(C <sub>s</sub> ) <sup>g</sup>	1.408	1.398	1.397	1.410	
[18]Annulene						
exptl <sup>h</sup>		1.405	1.385	1.385	1.405	
SINDO1 <sup>d</sup>	(D <sub>3h</sub> )	1.358	1.495	1.361	1.502	11.5
	(D <sub>6h</sub> )	1.423	1.418	1.418	1.423	0
MNDOC <sup>i</sup>	(D <sub>3h</sub> )	1.348	1.455	1.349	1.470	6.4
	(D <sub>6h</sub> )	1.400	1.398	1.398	1.400	0
HF/6-311G* <sup>f</sup>	(D <sub>3h</sub> )	1.342	1.457	1.333	1.477	0
	(D <sub>6h</sub> )	1.401	1.386	1.386	1.401	22.2
BLYP/6-311G* <sup>f</sup>	(D <sub>6h</sub> ) <sup>j</sup>	1.419	1.402	1.402	1.419	
B3LYP/6-311G* <sup>f</sup>	(D <sub>6h</sub> ) <sup>j</sup>	1.409	1.392	1.392	1.409	
MP2/6-31G* <sup>f</sup>	(D <sub>6h</sub> ) <sup>j</sup>	1.411	1.395	1.395	1.411	

<sup>a</sup> Defined in **5**, **10** (in Å). <sup>b</sup> Relative energy in kcal/mol within the same system and the same method. <sup>c</sup> Reference 16. <sup>d</sup> Reference 2a. <sup>e</sup> Reference 7c. <sup>f</sup> Fully optimized, this work. <sup>g</sup> Geometry optimizations starting with C<sub>i</sub> and C<sub>2h</sub> structures converged to the C<sub>s</sub> structure. <sup>h</sup> Reference 18. <sup>i</sup> Reference 10. <sup>j</sup> Geometry optimizations starting with D<sub>3h</sub> structures converged to the D<sub>6h</sub> structure.

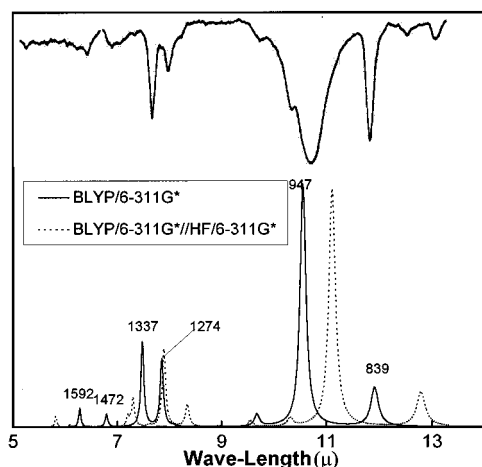
**Figure 1.** Experimental<sup>21</sup> and theoretical IR spectra of [18]annulene. The theoretical peaks are identified with the corresponding wavenumbers.

Infrared spectra of [18]annulene have been calculated with BLYP/6-311G\* at the BLYP/6-311G\* optimized geometry and at the HF/6-311G\* optimized geometry (localized structure). These are presented in Figure 1 and compared with experiment.<sup>21</sup> The frequencies as calculated at the BLYP optimized structure are in better agreement with experiment than those obtained at the localized structure lending further support to the delocalized structure of [18]annulene. A similar conclusion has been reached for the symmetry breaking problem in azulene by Kozłowski et al.<sup>22</sup> using B3LYP.

One important result of our electron correlation calculations on [14]annulene and [18]annulene is that, irrespective of the

(19) Bregman, J.; Hirshfeld, F. L.; Rabinovich, D.; Schmidt, G. M. J. *Acta Crystallogr.* **1965**, *19*, 227.

(20) Capponi, S.; Guihéry, N.; Malrieu, J.; Miguel, B.; Poilblanc, D. *Chem. Phys. Lett.* **1996**, *255*, 238.

(21) Sondheimer, F.; Wolovsky, R.; Amiel, Y. *J. Am. Chem. Soc.* **1962**, *84*, 274.

(22) Kozłowski, P. M.; Rauhut, G.; Pulay, P. *J. Chem. Phys.* **1995**, *103*, 5650.

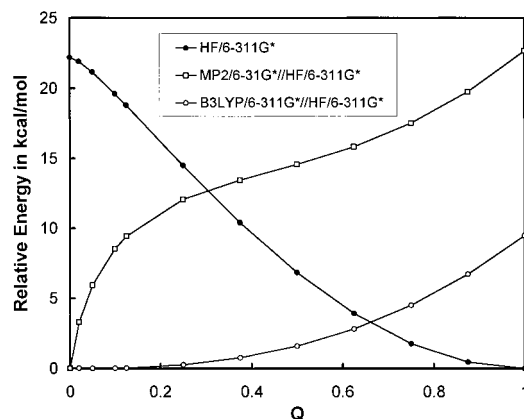
**Figure 2.** Relaxed potential energy surface scan along the Q coordinate with the optimized HF/6-311G\* method and with nonoptimized B3LYP/6-311G\* and MP2/6-31G\* single point energy evaluations at each HF/6-311G\* optimized geometry.

chosen starting symmetry, the geometry optimizations invariably ended up with the delocalized, more symmetrical structures, indicating that the potential surfaces of these two annulenes have only one minimum, **3**, **8** along the  $\delta$  coordinate, in complete agreement with experiment.

This observation casts doubt on the validity of using HF and semiempirical methods for determining relative stabilities of localized and delocalized structures of conjugated molecules.

To study the potential energy surface along the  $\delta$  coordinate, a numerical scheme connecting the HF/6-311G\* optimized structures of the D<sub>6h</sub> and D<sub>3h</sub> symmetry of [18]annulene is proposed, that is,  $R_i^\delta = QR_i(D_{3h}) + (1 - Q)R_i(D_{6h})$ , where R<sub>i</sub> is the i-th C-C bond length of [18]annulene and Q ranges from 0 to 1. Except for R<sub>i</sub><sup>δ</sup>, all other geometric parameters have been optimized with HF/6-311G\* followed by a single point energy evaluation with MP2/6-31G\* and B3LYP/6-311G\* at the HF/6-311G\* optimized geometry (see Figure 2). This path connects the minima of the HF/6-311G\* potential surface, starting at the aromatic minimum and ending at the localized one. This is an unambiguous way to define the hypothetical localized structure, and this linear path offers a viable qualitative description. HF clearly overestimates the stability of the localized structure (Q = 1). We have not found in the correlated calculations any barrier between the two structures. The B3LYP curve is gradually increasing showing no sign of a minimum, or even an inflection around Q = 1 or any other Q ≠ 0 value. The MP2 curve raises sharply for even just 25% distortion along Q, and then further raises gradually, not showing any sign of another minimum. The pathological behavior disappears for larger Q values, and the MP2 and B3LYP curves run parallel above Q ≈ 0.5.

In summary, the general picture of the three minima along the  $\delta$  (Kekulé) coordinate of annulenes that has been implied by most earlier computations is being disputed in this communication. As far as [14]- and [18]annulenes are concerned, there is only one minimum in complete agreement with experiment. We do not yet know at which size the "transition" to the other type of potential surface occurs and whether the potential surface will have two or three minima. "Transition", which is a consequence of Peierls' theorem is expected to occur in annulenes larger than C<sub>18</sub>H<sub>18</sub>.

**Acknowledgment.** Dedicated in honor of the 60th birthday of Roald Hoffmann. We thank the National Science Foundation (CHE-9601976 and NCSA, No. CHE-950029N) for support. Ample supply of computer time from the computer center and the Institute of Theoretical Chemistry and Radiation Chemistry of the University of Vienna is gratefully acknowledged.